

Data Sheet

TouchMonitor TM7 Series

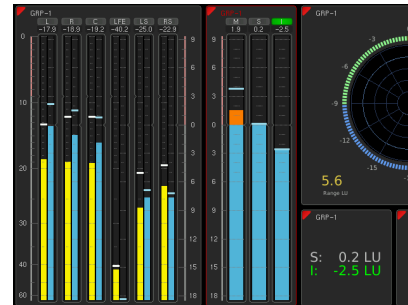

TouchMonitor TM7 Series



Modular Software • Touch Screen • I/O Options: Analog, AES3, AES3id, 3G SDI, AoIP • Highly Flexible Screen Layout • 2-ch. PPM/True Peak • Multichannel • Loudness • LRA • Logging • Chart • Timecode • SPL • RTA • SSA • Radar • Premium PPM • BLITS

The TouchMonitor TM7 range enters a new level of professional audio metering in terms of precision, performance, efficiency and flexibility. The units are equipped with high-grade 7" touch screens, an easy-to-use graphical user interface, and several audio interfaces.

TouchMonitor TM7 handles audio signals using different audio interfaces: analog, AES3, AES3id, 3G-SDI, and AoIP. The mixed use of the analog and digital audio interfaces allows the display of up to 16 (24) input channels simultaneously. The AoIP interfaces provide up to 32 channels.

Graphical User Interface

The graphical user interface used in the TouchMonitor range is controlled simply by using your finger. Instruments can be scaled, randomly positioned and combined for optimized use of available screen space. Multiple instruments of the same type, assigned to different input channels and configurations, can be displayed simultaneously. A comprehensive on-screen help feature supports the user to make setup changes with ease.

Licences

A totally modular software concept means that you only have to purchase features that you actually require. This puts you in control, defining the functionality of an individual TouchMonitor that suits your needs best. At any time new instruments and functions can be added to the device as software modules simply by purchasing and activating a corresponding licence.

Gefördert durch:



aufgrund eines Beschlusses
des Deutschen Bundestages

Hardware

Common Configuration

- 7" touch screen 16 : 9 TFT (800 x 480 pixel)
 - 16-, 24-, or 32-channel audio interfaces (analog, AES3, AES3id, 3G-SDI, AoIP, selection required)
 - Connectors for Ethernet, VGA, 2 x USB 2.0, GPIO, (12) 24 V DC
 - Fully scalable, modular software approach for flexible configuration and easy on-site upgrades
 - Highly flexible screen layout options with scalable instruments
 - Basic 4-channel PPM software: Peak, True Peak, Phase Meter, Global Keyboard
 - Table-top unit, OEM version, or preconfigured models
 - Mounting kits for mounting into 19"/3U racks resp. 19" video racks available
- Available software licences (see **Software** section):
 - Multichannel
 - Loudness (EBU R128, ITU, ATSC A/85, ARIB, OP-59, AGCOM, CALM, LEQ(M), TASA, SAWA) und SPL
 - RTA - Real Time Analyzer
 - SSA - Surround Sound Analyzer
 - Radar Display,
 - Premium PPM plus Vectorscope
 - Timecode Reader (reader and recalculation)
 - BLITS (analyzer and generator)
 - Logging Data Server (external logging or chart)
 - ISA - Immersive Sound Analyzer

Main Units

20700

TouchMonitor TM7 main unit in a sturdy table-top frame with movable table-stand and power supply. Additionally, the selection of an audio interface is required.



20700OEM

TouchMonitor TM7 main unit without table-top frame, without table-stand and without power supply, for mounting into front panels, e. g. mixing consoles. Additionally, the selection of an audio interface is required.



Audio Interfaces (I/O Options)

Each main unit comes with an audio interface, which will be fitted to a new unit by factory. On the next page you will find the available audio interfaces. Select the interface suited to your needs and tell us its additional order number when ordering a new main unit.



Hardware (continued)

HW20711



16-channel audio interface with:

- 8-channel analog inputs (electronically balanced, Sub-D)
- 8-channel digital inputs and outputs (transformer balanced, 110 Ohm, 4 x AES3 In/Out, Sub-D)

HW20712



16-channel audio interface with:

- 8-channel analog inputs (electronically balanced, Sub-D)
- 8-channel digital inputs and outputs (unbalanced, 75 Ohm, 4 x AES3id In, 4 x AES3id Out, 8 x BNC)

HW20714



8-channel audio interface and 3G-SDI interface with:

- 8-channel digital inputs and outputs (transformer balanced, 4 x AES3 In/Out, Sub-D)
- 3G/HD/SD-SDI interface (unbalanced, 75 Ohm, 3G-SDI In, 3G-SDI Through, 2 x BNC)

HW20715



16-channel audio interface with:

- 16-channel digital inputs and outputs (transformer balanced, 110 Ohm, 8 x AES3 In/Out, 2 x Sub-D)

HW20717



32-channel audio interface with:

- 32 Dante® AoIP network channels (2 x RJ-45, Primary/Secondary)

HW20718



32-channel audio interface with:

- 32 Ravenna/AES67/ST 2110 AoIP network channels (2 x RJ-45, Primary/Secondary)

Additional Hardware Options

TM7-MA3U (3U Mounting Adapter for 207000EM)

Mounting kit including a 19"/3U/42HP rack-mount panel (half-19"/3U) and fastening material for mounting 207000EM into standard 19" sub-racks.

TM7-MAVID (VID Mounting Adapter for 207000EM)

Mounting kit including a half-19"/3U plug-in panel and fastening material for mounting 207000EM into standard 19" rack-mount cabinets for video racks.

TM7-MADT (Table-top Mounting Adapter for 207000EM)

Mounting kit including a table-top frame, robust swivel-mounted table-stand, housing cover, and mounting material for remodelling 207000EM to a table-top unit.

1647831 (19"/3U rack frame)

for mounting up to 2 TM7-Mount or 207000EM in conjunction with TM7-MA3U mounting kit. Includes a blank panel to cover unused space.



Hardware (continued)

Preconfigured Models

The models are already preconfigured for typical application fields and equipped with a corresponding audio interface. As the previously described devices, they can be expanded with software modules (licences). We recommend licences SW20001 for multi-channel operation, SW20002 for loudness measurements and SPL display, SW20004 for the use of the Surround Sound Analyzer, and SW20006 for up to four audio vectorscopes, Multistandard PPM/VU moving coil emulations as basic configuration for the following units. Further licences can be found in the **Software** section.

TM7-RAV

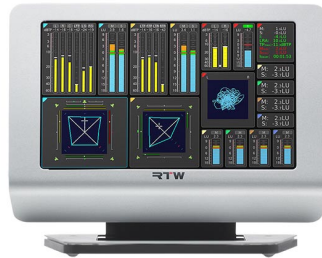
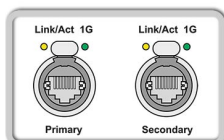

- 7" table-top unit for AoIP network-based post production, TV broadcast and video editing
- 32 Ravenna AoIP network channels (2 x RJ-45, Prim./Sec.)
 - Power supply 12 - 24 V DC, 24 VA

TM7-Dante

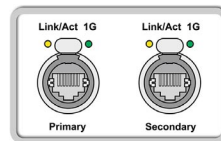

- 7" table-top unit for AoIP network-based post production, TV broadcast and video editing
- 32 Dante® AoIP network channels (2 x RJ-45, Prim./Sec.)
 - Power supply 12 - 24 V DC, 24 VA

TM7-Video

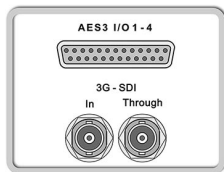

- 7" table-top unit for post production, TV broadcast, video editing
- 8-ch. digital inputs and outputs (4 x AES3 In/Out, Sub-D)
 - 3G-/HD-/SD-SDI In/Through (2 x BNC)

TM7-Studio

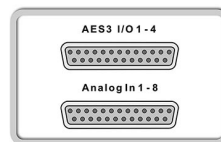

- 7" table-top unit for audio production, post production
- 8-ch. analog inputs (Sub-D)
 - 8-ch. digital inputs and outputs (4 x AES3 In/Out, Sub-D)

TM7-Rack

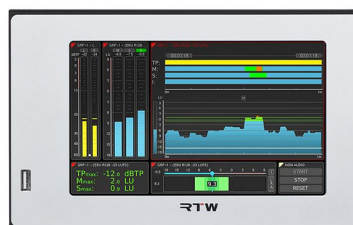
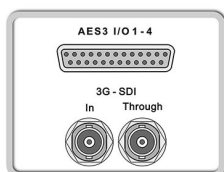

- 7" rack-mount unit for TV broadcast, post production
- 8-ch. digital inputs and outputs (4 x AES3 In/Out, Sub-D)
 - 3G-/HD-/SD-SDI In/Through (2 x BNC)

TM7-Mount

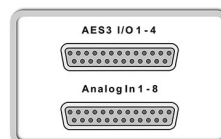

- 7" panel-mount unit for TV broadcast, post production
- 8-ch. analog inputs (Sub-D)
 - 8-ch. digital inputs and outputs (4 x AES3 In/Out, Sub-D)

Software

Standard Software

Every TouchMonitor comes with a basic software package. Beside the control functions, this software is able to process the signals of up to 4 routed channels in a maximum count of 4 groups at a time (up to 4 x Mono, 2 x 2-channel Stereo, 1 x 2-channel Stereo and up to 2 x Mono; no 3.1). Available for display are: 4-channel PPM with analog scales (DIN5, Nordic, British IIa, British IIb) and digital scales (0 to -60 dB, +3 to -60 dB TruePeak, DIN5, Nordic, British IIa and IIb), peak hold, peak memory, Over indicators, phase correlation meter and a global keyboard for simultaneous control of defined functions in multiple instruments and for preset recall. It also allows the external control with the integrated GP IO interface. Optional licences expand the feature set with a multichannel option and other software modules.

Software Modules (Licences)

Software modules can be ordered as licences either together with the order of the main unit and the selected audio interface or at a later point in time. Together with the order of the main unit the licence will be activated at delivery.

When a licence is needed at a later point in time, the order process is started from the "Licences" menu of the TM7 unit. A device-specific file for forwarding to RTW is created by the unit. RTW will send back a corresponding file with the activated licence for exactly this unit.

SW20001: Multichannel Mode

Expands the signal routing to the simultaneous display of more than 4 channels or channel groups. Additional formats: 3.1 Surround, 5.0 Surround, 5.1 Surround, 7.1 Cinema Surround, 7.1 DD+ Surround, and Multichannel (2 to 8 channels in one block, up to 4 blocks with 3G SDI option).

SW20002: Loudness and SPL Display

Expands the basic Stereo-PPM with Loudness functions (EBU R128, ITU-R BS.1770-4/1771-1, ATSC A/85, ARIB, OP-59, AGCOM, CALM, LEQ (M), TASA, SAWA), SPL functions, and Loudness Range instrument (LRA). For the display of more than 4 ch. Licence SW20001 is required. Then, Dialnorm is available.



SW20003: RTA - Real Time Analyzer

Provides on 31, 61 or 120 bands a spectral distribution display of the frequency range of single channels, channel pairs or groups. Additional HP HF band available. Licence SW20001 is required for the display of more than 4 channels.

SW20004: SSA - Surround Sound Analyzer

Dynamic display for visualizing the interaction of all technical and subjective surround sound parameter corresponding to the subjective listening impression. --- Precondition: Licences SW20001, SW20002! ---

SW20005: Radar Display

High resolution circular Loudness display corresponding to the Loudness Radar Meter of TC electronic®.

Licence SW20001 is required for the display of more than 4 channels.

--- Precondition: Licence SW20002! ---

SW20006: RTW Premium PPM + Vectorscope

High resolution Multistandard-PPM display with advanced scales, moving coil instruments (PPM, VU, Loudness, BBC mode), and with Audio Vectorscope (4 instances). Expands licence SW20001 with Multi-Correlator, if activated. Licence SW20002 is required for the display of Loudness.



Software (continued)

SW20008: Timecode Reader

Decoding of SDI embedded or LTC timecode. Timecode display. Licence SW20002 is required for the possibility of recalculating loudness.

SW20013: BLITS

Tool to generate line test signals according to EBU 3304, GLITS and BLITS definition. Automatic and significant analysis of channel allocation, level, phase and delay, and polarity of received BLITS 5.1 test signals.

--- Precondition: Licence SW20001! ---

SW20014: Logging Data Server

Export of measured data via IP connection or USB flash drive. Two-stage definition of thresholds. Advanced graphical presentation with RTW LQL PC software. Chart instrument for the display of the course of a measurement directly on the TM.

--- Precondition: Licence SW20002! ---

SW20015: ISA - Immersive Sound Analyzer

Visualisation of the dynamic behaviour and interaction of all relevant technical and subjective parameters of immersive surround signals across two layers. Intuitive evaluation of the spatial balance at a glance.

--- Precondition: Licences SW20001, SW20002, SW20004! ---

SW20021: TC-RTW

Licence to convert TouchMonitor devices of TC electronic® to RTW units to allow the installation of upcoming licences with new product functionalities.

--- Precondition: TouchMonitor devices of TC electronic®! ---



PC Software: LQL - Loudness Quality Logger

Logging console for Windows® OS to collect and store timecode or realtime based Loudness and True Peak data via IP connection (LAN connector) or USB stick of multiple TM7, TMR7, and TM9 with LQL licence SW20014 activated. Two-stage definition of limits to generate various alarms, status overview, reports, and data export. The basic version is available for free to registered users. Please see members area of RTW's web site (Support/Manuals & Software) under „PC Software/LQL - Loudness Quality Logger“ (please log in).

--- Precondition: Licence SW20014 must be installed on each connected TouchMonitor ---

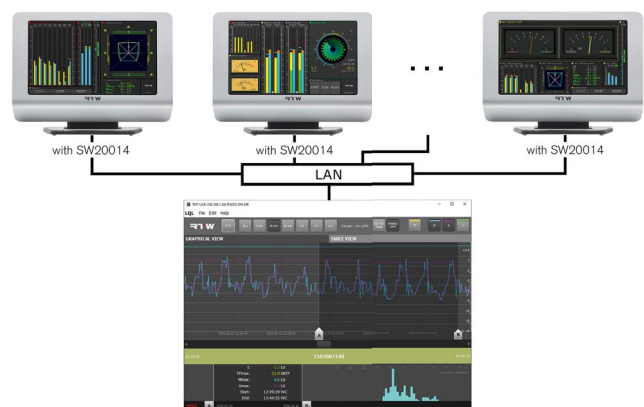

The Loudness Radar Meter is trademark or registered trademark of TC Electronic A/S, 8240 Risskov, Denmark

Dimensions

TouchMonitor TM7 20700 Table-Top Unit (20700 + HW2071n, also 20700OEM + HW2071n with TM7-MADT, TM7-RAV, TM7-Dante, TM7-Video, TM7-Studio)

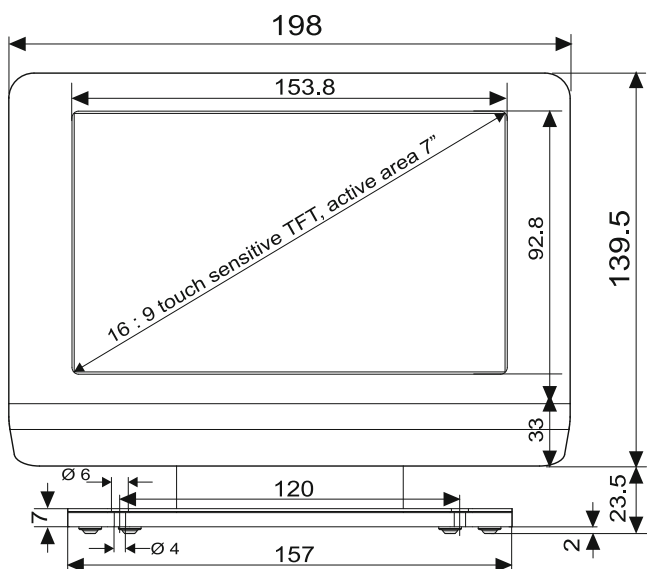

1 | Front view (dimensions in mm)

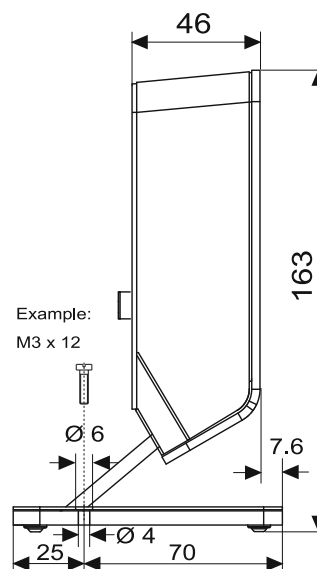

2 | Side view (dimensions in mm)

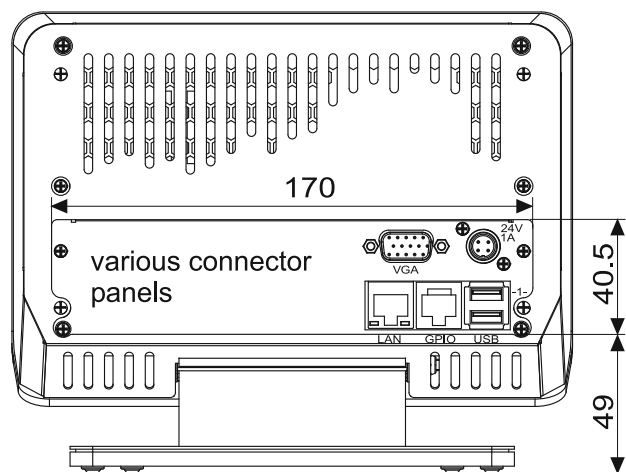

3 | Rear view (dimensions in mm)

Common tolerance: ± 0.5 mm

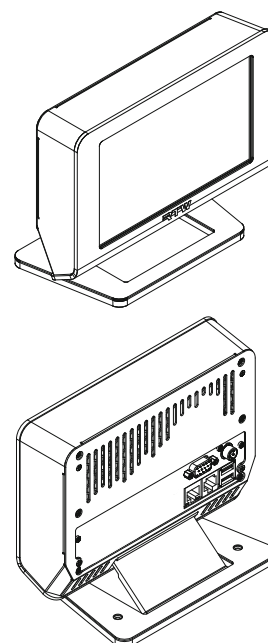

Dimensions (continued)

TouchMonitor TM7 20700OEM OEM Mounting Version (20700OEM + HW2071n, also TM7-Mount)

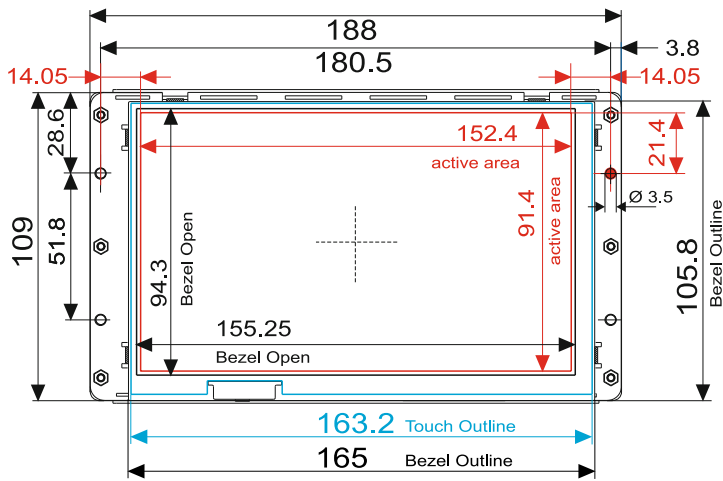

1 | Front view (dimensions in mm, tolerance: ± 0.2 mm)

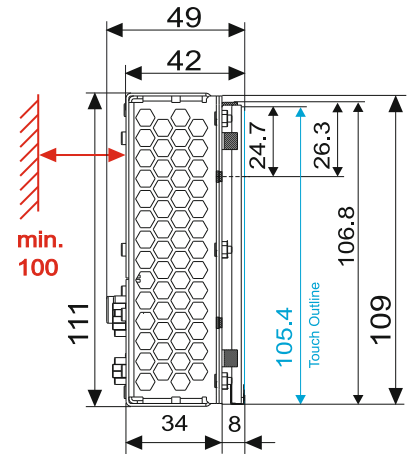

2 | Side view (dimensions in mm, tolerance: ± 0.5 mm)

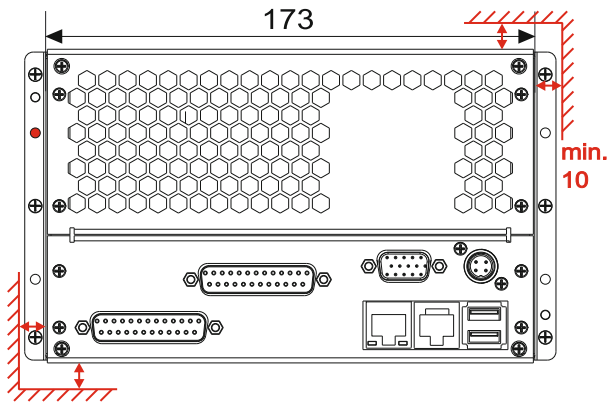

3 | Rear view (dimensions in mm, tolerance: ± 0.5 mm)

! For adequate ventilation a minimum space is required:
 min. 10 mm at all sides and
 min. 100 mm on the rear side!

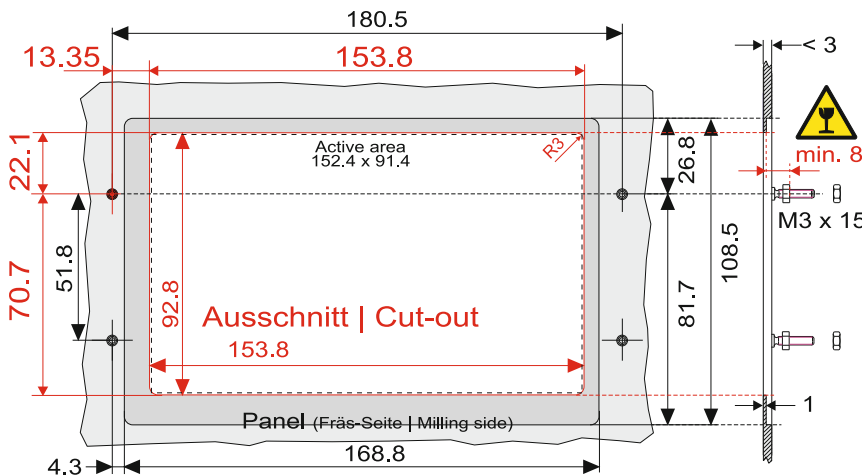
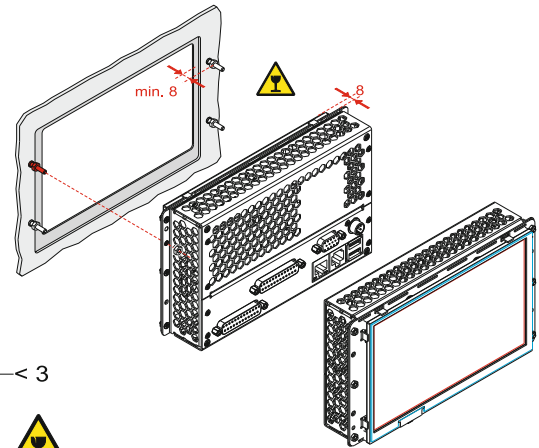

4 | Front panel cut-out (dimensions in mm, tolerance: ± 0.2 mm)

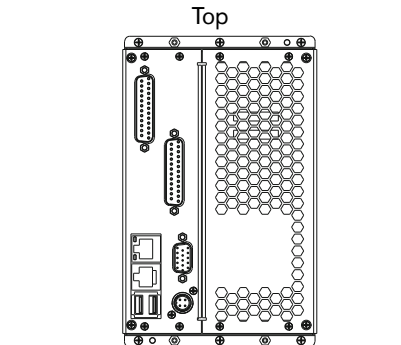

5 | Vertical mounting orientation

Dimensions (continued)

Optional TM7-MA3U Mounting Adapter for Mounting 20700OEM into Standard Racks

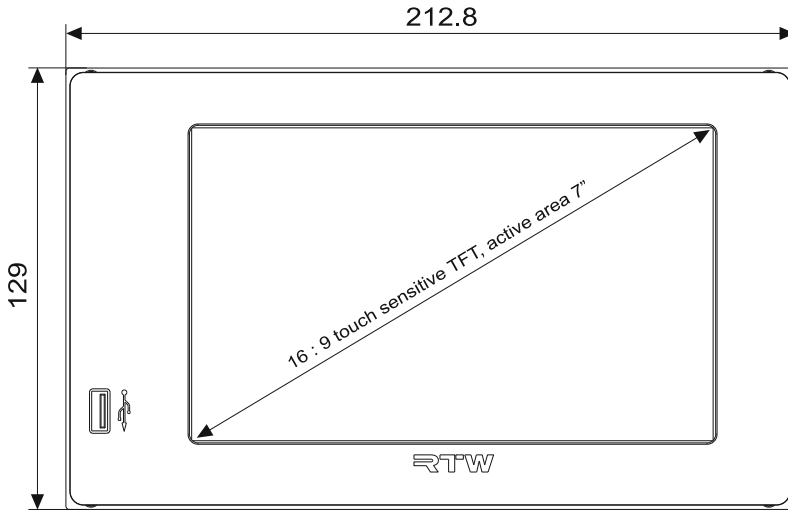

1 | Front view (dimensions in mm)

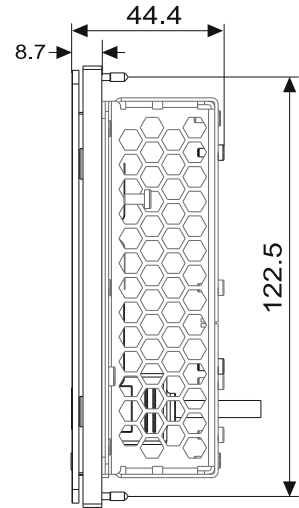

2 | Side view (dimensions in mm)

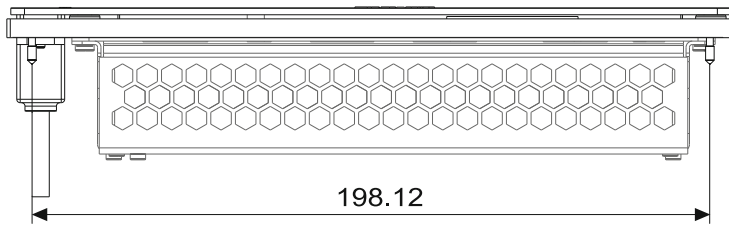

3 | Top view (dimensions in mm)

Optional TM7-MA3U with 20700OEM fits to standard 19"/3U sub racks (DIN EN 60297-3-101:2004 19"/3U/84HP)

Common tolerance: ± 0.5 mm

20700OEM and sub rack are not part of TM7-MA3U delivery

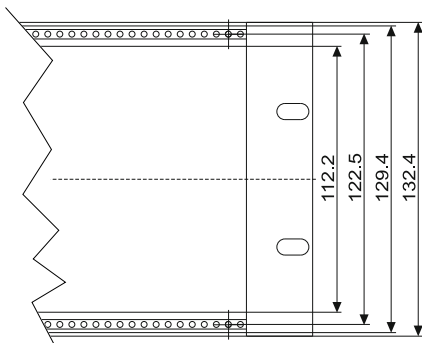

4 | Heights (mm) of standard 19"/3U sub racks

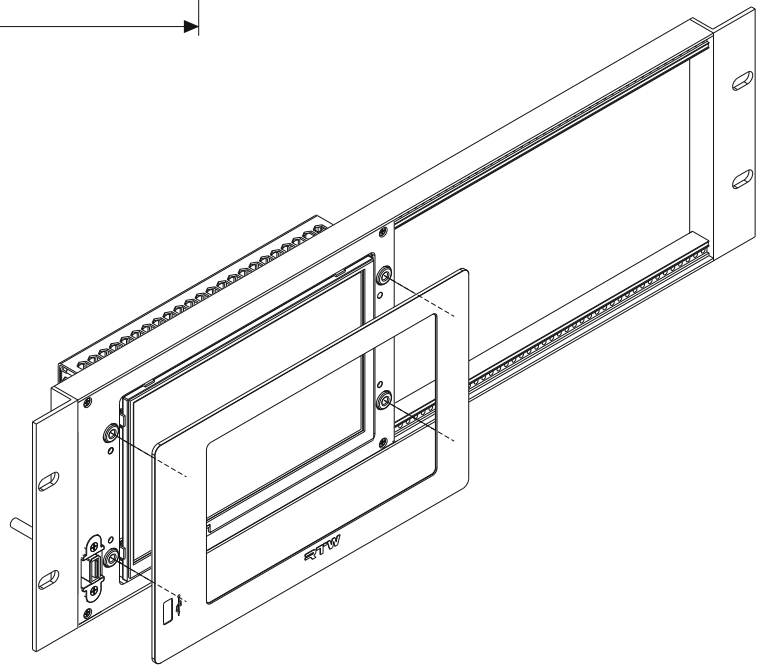

5 | Mounting into standard 19"/3U sub rack



Dimensions (continued)

Optional TM7-MAVID Mounting Adapter for Mounting 20700OEM into Video Racks (also TM7-Rack)

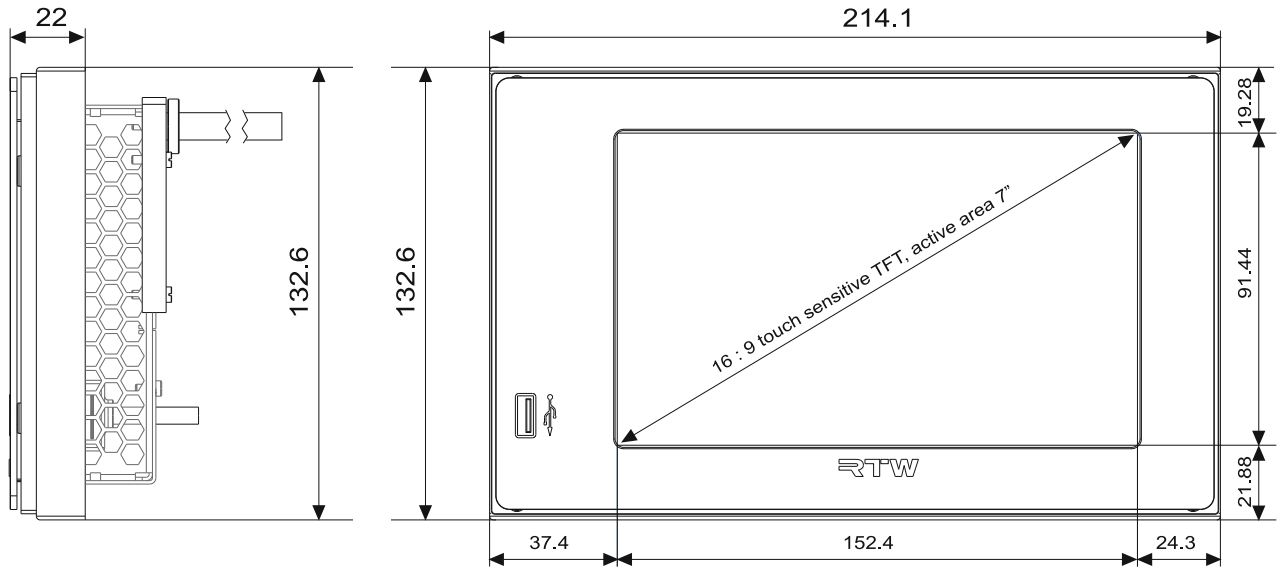

1 | Side view (dimensions in mm)

2 | Front view (dimensions in mm)

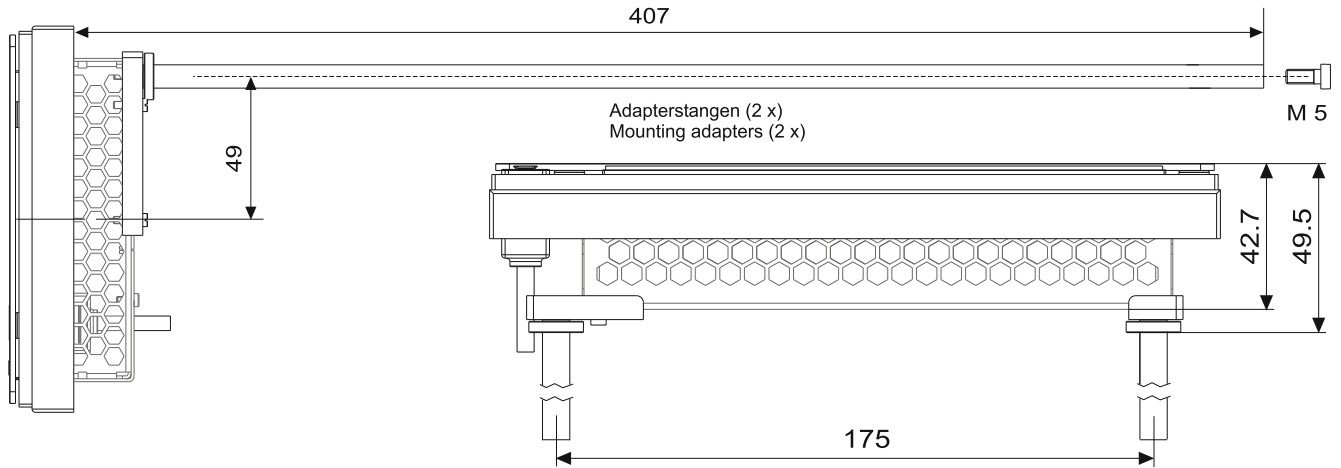

3 | Mounting depth (side view with adapters, dimensions in mm)

4 | Top view (dimensions in mm)

Common tolerance: $\pm 0,5$ mm

Optional TM7-MAVID with 20700OEM fits into standard 19" rack-mount cabinets for waveform monitors in video studios

20700OEM and rack-mount cabinet are not part of TM7-MAVID delivery

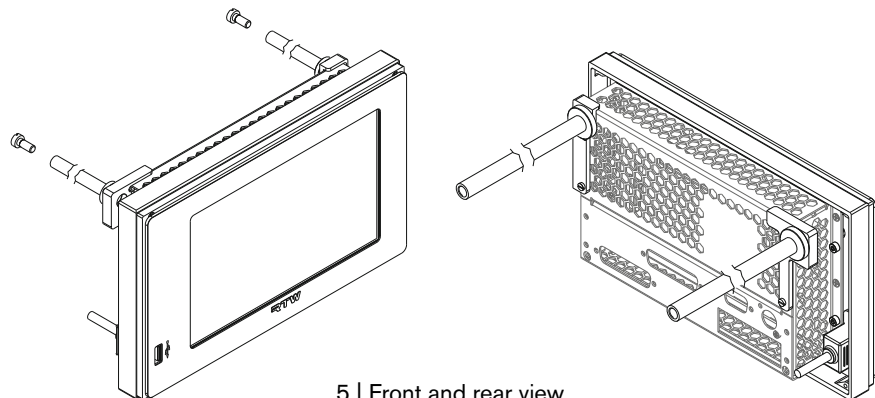

5 | Front and rear view

Connection



ATTENTION! - For operating the 20700OEM version or models TM7-Rack and TM7-Mount, an adapted mains adapter is required. RTW recommends the use of the RTW wide voltage power supply 1178-R (100 - 240 V AC/24 V DC, 2.71 A) approved for TouchMonitor and available as an accessory. For 20700OEM and its combinations with mounting adapters TM7-MA3U, TM7-MAVID, or TM7-MADT, or for TM7-Rack and TM7-Mount it has to be ordered separately. This power supply is already included in the 20700, TM7-RAV, TM7-Dante, TM7-Video and TM7-Studio packages.



NOTE - Some devices may have a DC input connector marked +12 V DC. These units may be operated with a nominal DC voltage in the range of +12 V to +24 V DC.

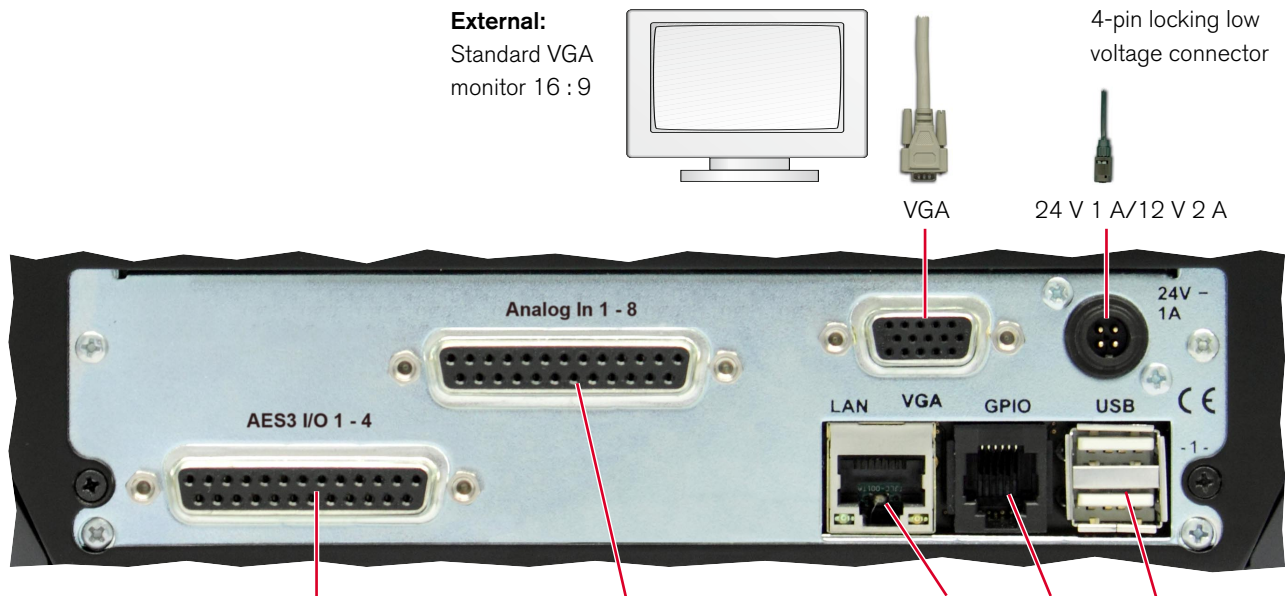

HW20711 (pictured):	AES3 In/Out 1 - 4 (Sub-D)	Analog In 1 - 8 (Sub-D)	LAN (RJ-45)	GPIO (RJ-12)	USB A 2.0 (Full Speed)
HW20712:	AES3id In/Out 1 - 4 (8 x BNC)	Analog In 1 - 8 (Sub-D)			
HW20714:	3G-SDI In/Through (2 x BNC)	Audio In/Out (Sub-D)			
HW20715:	AES3 In/Out 1 - 4 (Sub-D)	AES3 In/Out 5 - 8 (Sub-D)			
HW20717/718:	Dante®/Ravenna AoIP	Dante®/Ravenna AoIP			
	Link/Act 1G Primary (RJ-45)	Link/Act 1G Secondary (RJ-45)			
TM7-Dante/ TM7-RAV:	Dante®/Ravenna AoIP	Dante®/Ravenna AoIP			
	Link/Act 1G Primary (RJ-45)	Link/Act 1G Secondary (RJ-45)			
TM7-Video:	3G-SDI In/Through (2 x BNC)	Audio In/Out (Sub-D)			
TM7-Studio:	AES3 In/Out 1 - 4 (Sub-D)	Analog In 1 - 8 (Sub-D)			
TM7-Rack:	3G-SDI In/Through (2 x BNC)	Audio In/Out (Sub-D)			
TM7-Mount:	AES3 In/Out 1 - 4 (Sub-D)	Analog In 1 - 8 (Sub-D)			



External:
 USB flash drive
 USB mouse
 Wacom® graphics tablet



Pin Assignment

Analog In 1 -8 (electr. bal., 25-pin Sub-D-F)

Pin:	Function:
1	Analog input 8 resp. 16 (+, hot)
14	Analog input 8 resp. 16 (-, cold)
2	Shield/chassis
15	Analog input 7 resp. 15 (+, hot)
3	Analog input 7 resp. 15 (-, cold)
16	Shield/chassis
4	Analog input 6 resp. 14 (+, hot)
17	Analog input 6 resp. 14 (-, cold)
5	Shield/chassis
18	Analog input 5 resp. 13 (+, hot)
6	Analog input 5 resp. 13 (-, cold)
19	Shield/chassis
7	Analog input 4 resp. 12 (+, hot)
20	Analog input 4 resp. 12 (-, cold)
8	Shield/chassis
21	Analog input 3 resp. 11 (+, hot)
9	Analog input 3 resp. 11 (-, cold)
22	Shield/chassis
10	Analog input 2 resp. 10 (+, hot)
23	Analog input 2 resp. 10 (-, cold)
11	Shield/chassis
24	Analog input 1 resp. 9 (+, hot)
12	Analog input 1 resp. 9 (-, cold)
25	Shield/chassis
13	not used

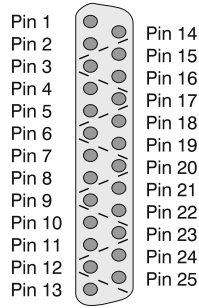

(External view of the connector)

AES3 I/O 1 - 4, AES3 I/O 5 - 8, Audio I/O (transf.-bal., 25-pin Sub-D-F)

Pin:	Function:
1	Digital output 4 resp. 8 (+, hot)
14	Digital output 4 resp. 8 (-, cold)
2	Shield/chassis
15	Digital output 3 resp. 7 (+, hot)
3	Digital output 3 resp. 7 (-, cold)
16	Shield/chassis
4	Digital output 2 resp. 6 (+, hot)
17	Digital output 2 resp. 6 (-, cold)
5	Shield/chassis
18	Digital output 1 resp. 5 (+, hot)
6	Digital output 1 resp. 5 (-, cold)
19	Shield/chassis
7	Digital input 4 resp. 8 (+, hot)
20	Digital input 4 resp. 8 (-, cold)
8	Shield/chassis
21	Digital input 3 resp. 7 (+, hot)
9	Digital input 3 resp. 7 (-, cold)
22	Shield/chassis
10	Digital input 2 resp. 6 (+, hot)
23	Digital input 2 resp. 6 (-, cold)
11	Shield/chassis
24	Digital input 1 resp. 5 (+, hot)
12	Digital input 1 resp. 5 (-, cold)
25	Shield/chassis
13	not used

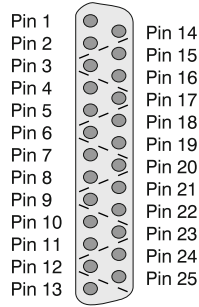

(External view of the connector)

NOTE - The AES3 inputs are permanently terminated with 110 Ω.

LAN

RJ-45 standard network connector (10/100 MBit)

Link/Act 1G (RJ-45 NE8FBV-C5-LED1-S connector)

RJ-45 AoIP network connection (Primary/Secondary)

NOTE - etherCON NE8MX-6-T/NE8MX6 connector with CAT-7-S/FTP cable and wired shield shall be used!

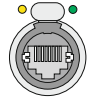

AES3id In/Out 1 - 4, 3G-SDI (unbal., BNC-F)

Pin: Function:

Pin: Signal
Ring: Shield/chassis



(External view of the AES3id connector)



(External view of the 3G-SDI connector)

NOTE - The AES3id inputs and the 3G-SDI inputs are permanently terminated with 75 Ω.

24 V - 1 A, 12 V - 2 A

(4-pin locking low voltage connector, Typ Binder 710)

Pin: Function:

1 - 2 +24 V DC/+12 V DC
3 - 4 0 V

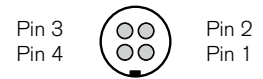

(External view of the connector)

NOTE - An external overcurrent protective device (2 A max.) shall be installed when using an external DC power supply!

USB-A

2 Full Speed USB 2.0 connectors for USB sticks (Licence handling, presets, updates) and external mouse or Wacom® tablet.

GP IO (RJ-12 6P6C socket)

External control of functions defined in the Global Keyboard menu. The inputs defined as „active low“ have to be switched against 0 V (Pin 1).

Pin: Function:

1 GND (0 V)
2 - 6 Function acc. to definition in the menu



(External view of the connector)

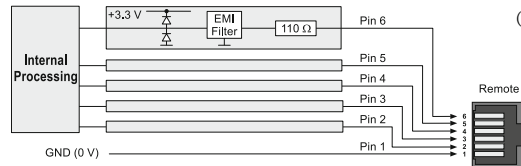

VGA (15-pin Sub-D-F)

Pin: Function:

1 R | Video signal
2 G |
3 B |
4 - 8 GND
9 +5 V
10 - 11 GND
12 SDA 14 V-sync
13 H-sync 15 SCI

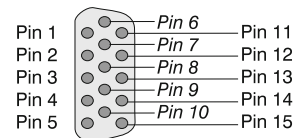

(External view of the connector)

NOTE - The VGA cable shall not exceed 15 m length!

Specifications

System

General

Power requirements:	+24 V DC (external 2 A max. overcurrent protective device shall be installed!) Some devices may have a DC input connector marked +12 V DC. These units may be operated with a nominal DC voltage in the range of +12 V to +24 V DC.
Current drain:	1 A nominal, 2.5 A power-up current (10 µsec.)
Power dissipation:	approx. 8.5 W (w/o SDI), approx. 11 W (with SDI)
Display:	7" TFT touch screen 16 : 9 (800 x 480 pixel)
Connectors:	1 x 15-pin Sub-D-F; VGA output with 800 x 480 pixel, 65.536 colors, 60 Hz, for connection of an optional external 16 : 9 VGA monitor, selectable 4 : 3 mode 1 x 4-pin locking low voltage connector type Binder 710 (DC) 2 x USB A; USB 2.0 Full Speed connectors for: <ul style="list-style-type: none"> USB memory sticks (licence handling, preset export and import, software updates) external computer mouse for operating external Wacom® graphics tablet 1 x GPIO (RJ-12-6P6C) for defined functions or preset recall 1 x LAN (RJ-45)
with HW20711:	2 x 25-pin Sub-D-F (analog and digital)
with HW20712:	1 x 25-pin Sub-D-F (analog), 8 x BNC-F (digital)
with HW20714:	1 x 25-pin Sub-D-F (digital), 2 x BNC-F (3G-SDI In, Through)
with HW20715:	2 x 25-pin Sub-D-F (digital)
with HW20717:	2 x RJ-45 (Dante® AoIP)
with HW20718:	2 x RJ-45 (Ravenna/AES67/ST 2110 AoIP)
Dimensions (W x H x D):	<ul style="list-style-type: none"> 20700: 198 x 163 x 46 mm 20700OEM: 188 x 109 x 45 mm - with TM7-MA3U: 42HP x 3U x 44.5 mm - with TM7-MAVID: 214.1 x 132.6 x 49.5 mm (429 mm depth with adapter rows), for video rack cabinets with 407 mm depth
Weight:	<ul style="list-style-type: none"> 20700: approx. 2.7 kg (w/o power supply) 20700OEM: approx. 1.2 kg
Operating temperature:	+5° to +40° C

Functions (with all licences activated)

- Operation with one finger (touch sensitive display) or a computer mouse
- Instruments can be scaled and freely positioned
- Multiformat Surround PPM (3.1, 5.0, 5.1, 7.1 Cinema, 7.1 DD+)
- 2-ch. and multichannel peakmeter
- Loudness-Meter: ITU-R BS.1770-4/1771, EBU R128, ATSC A/85, ARIB, OP-59, AGCOM, CALM Act, LEQ(M), TASA, SAWA, custom mode
- Loudness Test Time Control
- Loudness Range instrument (LRA)
- Logging Data Server
- Loudness Chart instrument
- Radar Loudness Meter (TC electronic®)
- SPL meter
- Timecode Reader, Loudness Recalculation

- Moving Coil (BR, VU, Loudness, BBC mode)
- Gain Reduction instrument
- Surround Sound Analyzer (up to 7.1 DD+)
- Stereo Correlator
- 10-fold Multi-Correlator with LFE mode
- 1/3-, 1/6-, 1/12-octave spectrum analyzer
- 2-channel Audio Vectorscope (4 instances)
- Dialnorm
- BLITS analyzer and generator
- AES3 status monitor
- Numerical displays
- Immersive Sound Analyzer (for 5.1.2, 5.1.4, 7.1.2, 7.1.4) and total Loudness

Analog Inputs

HW20711:	8 analog inputs, Sub-D-F connector, 25-pin
HW20712:	8 analog inputs, Sub-D-F connector, 25-pin adjustable in the range from 0 dBu to +10 dBu
Reference level:	+24 dBu
Maximum input level:	> 10 kΩ, electronically balanced
Impedance:	20 Hz to 22 kHz @ 48 kHz
Frequency range:	

Digital Inputs

HW20711:	4 AES3 inputs (transformer balanced, 110 Ω), Sub-D-F connector, 25-pin, 4 in-and 4 outputs
HW20712:	4 AES3id inputs (unbalanced, 75 Ω), 8 BNC-F connectors, 4 inputs and 4 outputs
HW20714:	4 AES3 inputs (transformer balanced, 110 Ω), Sub-D-F connector, 25-pin, 4 in-and 4 outputs and 3G-SDI interface with 2 x BNC-F connectors In and Through
HW20715:	8 AES3 inputs (transformer balanced, 110 Ω), 2 x Sub-D-F connector, 25-pin, 4 in-and 4 outputs each
Sampling rates:	44.1, 48, 96 kHz, synchronisation to digital input signal

Digital Outputs

HW20711:	4 AES3 outputs, Sub-D-F connector, 25-pin, with 4 inputs and 4 outputs
HW20712:	4 AES3id outputs, 8 BNC-F connectors, 4 inputs and 4 outputs
HW20714:	4 AES3 outputs, Sub-D-F connector, 25-pin with 4 inputs and 4 outputs and 3G-SDI interface with 2 x BNC-F connectors In and Through
HW20715:	8 AES3 outputs, 2 x Sub-D-F connector, 25-pin, 4 in-and 4 outputs each
Sampling rates:	referenced to digital inputs or internal clock

AoIP

HW20717:	32 Dante® AoIP network channels, 2 x RJ-45 connectors (Primary, Secondary) <ul style="list-style-type: none"> Sampling rates: <ul style="list-style-type: none"> Dante® interface: 44.1, 48, 88.2, 96 kHz for all 32 channels AES67 implementation: 44.1, 48 kHz only
HW20718:	32 Ravenna/AES67/ST 2110 AoIP network channels, 2 x RJ-45 connectors (Primary, Secondary) <ul style="list-style-type: none"> Sampling rates: 44.1, 48, 88.2, 96 kHz for all 32 channels



Specifications (continued)

Basic 4-Channel PPM (Standard Software)

General

Input sources:	analog, digital, 3G-SDI, AoIP, depending on selected audio interface
4-channel Peakmeter:	up to 4 x Mono, 2 x Stereo, 1 x Stereo and up to 2 x Mono (no 3.1)
Display:	<ul style="list-style-type: none">max. of 4 ch. total in max. 4 groupsPeak levelPeak holdNumerical value of the display
Functions:	<ul style="list-style-type: none">Gain (+20 dB, +40 dB acc. to standard)Peak hold on/offMemoryReset

Analog Peakmeter

Analog scales:	<ul style="list-style-type: none">DIN5: +5 .. -50 dB,Nordic: +12 .. -42 dB,BR IIa: 7 .. 1, BR IIa ext: 7 .. 1,BR IIb: +12 .. -12 dB, BR IIb +12 .. -12 dB, acc. to standard or 20 ms, 10 ms, 1 ms, 0,1 ms additional 150 ms for British scales
Integration time:	
Peak hold indicator:	1, 2, 4, 10, 20, 30 s, manual reset or off

Digital Peakmeter

Word width:	24 bit
Digital scales:	<ul style="list-style-type: none">TP60: +3 .. -60 dBDig60: 0 .. -60 dBDIN5: +5 .. -50 dBNordic: +12 .. -42 dBBR IIa: 7 .. 1, BR IIa ext: 7 .. 1,BR IIb: +12 .. -12 dB, BR IIb +12 .. -12 dB,
Headroom/Headroom Ref:	adjustable from 0 to -20 dB in steps of 1 dB
Operation field:	adjustable from 0 to -20 dB in steps of 1 dB
Integration time (Attack):	acc. to corresponding standard or selectable: Sample, 20 ms, 10 ms, 1 ms, 0,1 ms, additional 150 ms for British scales
Gain:	+20 dB, +40 dB (acc. to standard)
High-pass filter:	Off, 5 Hz, 10 Hz, 20 Hz
Peak hold indicator:	1 s, 2 s, 4 s, 10 s, 20 s, 30 s, manual reset or off
Over indicator hold time:	1 s or manual
Over indicator PPM	
- Threshold:	Full Scale, Full Scale -1LSB, Full Scale -2LSB, -0.1 dBFS, -0.5 dBFS, -1 dBFS, -2 dBFS, -3 dBFS
- Attack time:	1 to 15 samples
- Word width:	16 to 24 bit, selectable
Over indicator True Peak	
- Threshold:	adjustable

Stereo Correlator

Display:	Bargraph, additional spot indicator between PPM bargraphs
Scale range:	-1 r to 0 to +1 r
Standard color setting:	<ul style="list-style-type: none">red: -1 r to -0.1 rwhite: 0 r (-0.1 r to +0.1 r)green: +0.1 r to +1 r
Attack/release time:	1.0 s/2.5 s

AES3 Status Monitor

Display:	<ul style="list-style-type: none">Channel data are displayed as plain text, hex or binaryChannel selectableAudio bit activityHardware status
----------	---

Global Keyboard

The Global Keyboard is used for simultaneous control of defined functions in multiple instruments, and for preset recall. It also allows the external control with the integrated GP IO interface.

Gain Reduction

(Operation only with connection to Studer® Vista consoles)	
Display:	1 bargraph for Stereo and Surround formats, up to 8 bargraphs in multi-channel mode
Input:	Data stream via TCP/IP and LAN (ethernet) interface
Input routing:	external featured streams selectable
Marker:	adjustable threshold for the definition of upper and lower display section
Colors:	32 colors for each bargraph section

Optional Licence SW20001: Multichannel Mode

Expands Basic 4-channel PPM to multichannel and surround functions and display. More than 4 channels and groups can be displayed simultaneously.

Input sources:	analog, digital, SDI and/or AoIP depending on selected audio interface
Surround Peakmeter:	for 3.1, 5.0, 5.1, 7.1 Cinema, 7.1 DD+ formats
Track layout :	selectable for 5.1 Surround: <ul style="list-style-type: none">SMPTE.TV: L, R, C, LF, LS, RSSMPTE.Film: L, LS, C, RS, R, LFDTS: L, R, LS, RS, C, LFL, C, R, LF, LS, RSFilm: L, C, R, LS, RS, LF preset for 7.1 Cinema Surround: <ul style="list-style-type: none">SMPTE (L, LC, C, RC, R, LS, RS, LF) preset for 7.1 DD+ Surround: <ul style="list-style-type: none">L, C, R, LS, RS, LSR, LFE
Multichannel Peakmeter:	2 to 8 single channels in one defined block (depending on the audio interface up to 4 blocks)
2-channel Peakmeter:	for different Stereo channel pairs
Single-channel Peakmeter:	for different Mono signals

Optional Licence SW20002: Loudness and SPL Display

Expands the Basic 4-channel PPM with functions for loudness measurement and for SPL display and summed SPL value calculation

For the display of more than 4 channels software licence SW20001 is required. Then, also the Dialnorm instrument is available.

EBU R128 Loudness Mode

ITU BS.1771 Loudness Mode

ATSC A/85 Loudness Mode

ARIB Loudness Mode

OP-59 Loudness Mode

AGCOM Loudness Mode

CALM Loudness Mode

LEQ(M) Loudness Mode

TASA Loudness Mode

SAWA Loudness Mode

Specifications (continued)

Customer Specific Loudness Mode

Display:	<ul style="list-style-type: none"> ▪ Bargraphs for each single channel (can be combined with PPM bargraphs) ▪ M bargraph (Momentary - summation of momentary loudness values of all channels for a short span of time) ▪ S bargraph (Short - loudness summation value of an adjustable dynamic time frame) ▪ I-Bargraph (Integrated - long term loudness value infinite or manual control) ▪ adjustable tolerance range for M, S, I for M, S, I values (labelling adjustable)
Numerical display:	for LRA, TPmax, Mmax, Smax, I-time values
Scales:	Loudness scale: <ul style="list-style-type: none"> ▪ EBU+9: +9 .. -18 LU ▪ EBU+3: +3 .. -18 LU ▪ EBU+18: +18 .. -36 LU ▪ EBU+9a: 14 .. -41 LUFS ▪ EBU+18a: -5 .. -59 LUFS ▪ EBU0: 0 .. -60 LUFS ▪ ITU+9: +9 .. -18 LU (Loudness Units) ▪ ITU0: 0 .. -30 LKFS ▪ ATSC0: 0 .. -60 LKFS ▪ ATSC0a: 0 .. -30 LKFS K filter acc. to ITU BS.1770
Weighting filter:	
Target Level:	<ul style="list-style-type: none"> ▪ -23 LUFS; adjustable in the range from -10 to -30 LUFS in steps of 1 LUFS ▪ -24 LKFS; adjustable in the range from -10 to -30 LKFS in steps of 1 LKFS
Time & Gate Momentary:	
- Window Time:	adjustable in the range from 200 ms to 1000 ms in steps of 100 ms
- Integration Time:	IEC 125 ms Fast, 250 ms (IRT), 500 ms, 750 ms, IEC 1000 ms Slow, 1500 ms, 2000 ms selectable
Time & Gate Short:	
- Integration Time:	3 s; time window adjustable from 1 to 20 s in steps of 1 s
Time & Gate Integrated:	
- Silence Gate:	<ul style="list-style-type: none"> ▪ -70,0 LUFS; adjustable in the range from -80,0 to -40,0 LUFS in steps of 0.5 LUFS, switchable ▪ -70,0 LKFS; adjustable in the range from -80,0 to -40,0 LKFS in steps of 0.5 LKFS, switchable
- Relative Gate:	-10,0 LU; adjustable from -40,0 LU to 0 LU in steps of 0.5 LUFS, switchable
Level adjustment for the summation:	<ul style="list-style-type: none"> ▪ 0.0 dB (L, R, C), adjustable between -3 and +3 dB in steps of 0.5 dB ▪ +1.5 dB (LS, RS, LSR, RSR), adjustable between -3 and +3 dB in steps of 0.5 dB ▪ Off (LFE), selectable: Off, 0 dB, 10 dB
Tolerance Levels:	
- TP Headroom:	-9,0 dB; adjustable from 0 to -20 dB in steps of 0.1 dB
- TP Over Sensitivity:	0.0 dB; adjustable from 0 to -20 dB in steps of 0.1 dB
- M High:	+1.0 LU; M tolerance above Target Level adjustable from 0 to 10 LU in steps of 0.1 LU
- M Low:	-1.0 LU; M tolerance below Target Level adjustable from 0 to -12 LU in steps of 0.1 LU
- S High:	+1.0 LU; S tolerance above Target Level adjustable from 0 to 10 LU in steps of 0.1 LU
- S Low:	-1.0 LU; S tolerance below Target Level adjustable from 0 to -12 LU in steps of 0.1 LU

- I High:	+1.0 LU; I tolerance above Target Level adjustable from 0 to 10 LU in steps of 0.1 LU
- I Low:	-1.0 LU; I tolerance below Target Level adjustable from 0 to -12 LU in steps of 0.1 LU

Loudness Test Time Control

Settings for operating automatic, semi-automatic or manual loudness measurements.

Start:	
- Functions:	Autostart after preset load, autostart with gate, autostart with gate and autoreset, manually via keys or GPI. With Timecode Reader licence (SW20008) activated additional control via timecode resp. timecode with recalculation.
- Level for gate:	-70,0 LUFS/LKFS; adjustable from -85 to -10 LUFS/LKFS in steps of 0.5 LUFS/LKFS
Stop:	
- Functions:	manually via keys or GPI, autostop with gate, autostop with gate and time. The stop function is automatically set and fixed to timecode, if the start function has been set to a timecode option.
- Level for gate:	-70,0 LUFS/LKFS; adjustable from -85 to -10 LUFS/LKFS in steps of 0.5 LUFS/LKFS
- Time for gate:	1 s; adjustable from 1 to 15 s in steps of 1 s

Loudness Range Instrument (LRA)

Display:	Graphical display of the Loudness Range
Mode:	selectable: LRA Bar, MagicLRA, MagicLRA + I, MagicLRA + I + Num
Scale range:	selectable: 6 LU, 10 LU, 20 LU, 30 LU
LRA low range:	2 LU; adjustable in the range from 1 to 20 LU in steps of 1 LU
Comfort zone:	4 LU; adjustable in the range from 1 to 20 LU in steps of 1 LU
LRA high range:	depends on the selected scale range and the spread of the comfort zone
Colors:	selectable for each range

SPL Meter Mode

Display:	<ul style="list-style-type: none"> ▪ Bargraphs for each single channel (can be combined with PPM bargraphs) ▪ Summation bargraph
Reference point:	adjustable in the range from 68 dB to 88 dB in steps of 1 dB
Weighting:	Linear, A (Leq(A)), C, CCIR (Leq(M)), k
Integration time:	Fast (125 ms), Slow (1 s)

Optional Licence SW20003: RTA - Real Time Analyzer

Spectral distribution display of the frequency range of single channels, channel pairs or groups. For the display of more than 4 channels software licence SW20001 is required.

Spectrum Analyzer (RTA)

Input sources:	selectable: all channels without LF, all channels, Front, Rear, L/R, single channels, Stereo pairs, depending on selected mode
Frequency range:	<ul style="list-style-type: none"> ▪ Norm: 20 Hz to 20 kHz, additional band > 20 kHz switchable ▪ LF: 5 Hz to 5 kHz
Number of bands:	<ul style="list-style-type: none"> ▪ 1/3-octave: 31 bands, filter acc. to IEC 225 class 2 ▪ 1/6-octave: 61 bands ▪ 1/12-octave: 120 bands
Weighting filter:	Linear; Linear, A, C selectable
Peak hold indicator:	1 s, 2 s, 4 s, 10 s, 20 s, 30 s, manual reset or off



Specifications (continued)

Measuring range:	45 dB max.
Scaling:	3, 6, 9 dB
Functions:	<ul style="list-style-type: none"> ▪ Input selection ▪ Peak hold on/off ▪ A, C, Linear weighting ▪ Integration time ▪ Set reference ▪ Scaling ▪ Frequency range ▪ Bargraph arrangement ▪ Display-Hold
Integration time (ballistics):	Impulse, Fast, Slow, Peak (10 ms)

Optional Licence SW20004: SSA - Surround Sound Analyzer

Dynamic display for visualizing the interaction of all surround parameter corresponding to the subjective listening impression
 --- Precondition: Software licences SW20001, SW20002 are activated. ---

Surround-Sound-Analyzer

Display:	<ul style="list-style-type: none"> ▪ Graphical display indicating the single channel and total program loudness acc. to selected weighting filter (Total Volume Indicator) acc. to selected weighting filters (e. g. SPL or Loudness) ▪ Position and width of phantom sound sources (PSI) ▪ Correlation of adjacent channels in PSI (color) resp. TVI (shape of line): red resp. funnel: negative range, yellow resp. straight line: "0" range, green resp. roof: positive range ▪ Separate correlators for the outer adjacent channels switchable: red: negative range, white: „0" range, green: positive range ▪ Dominance indicator (DMI) ▪ LFE Phase (warning display, if correlation between any channel and LFE is negative)
----------	--

Optional Licence SW20005: Radar Display

High resolution circular Loudness display corresponding to the Loudness Radar Meter of TC electronic®.
 --- Precondition: Software licence SW20002 is activated. ---
 For the display of more than 4 channels software licence SW20001 is required.

Radar Loudness Meter

Display:	<ul style="list-style-type: none"> ▪ Momentary Loudness values (circular) ▪ History (circular) ▪ Measuring time (numerical) ▪ 2 Loudness descriptors (numerical) ▪ Peak
Mode:	Radar or Statistics
Sliding Loudness:	3 s, 6 s, 10 s, 15 s, 30 s, 1 min, 2 min, 4 min, 8 min
Descriptors:	Off, Program Loudness, Loudness Max, Loudness Range, Sliding Loudness (max. 2 at a time)
Speed:	1, 4, 12, 30 min, 1, 2, 4, 12, 24 h
Resolution:	3 dB, 4 dB, 6 dB, 8 dB, 10 dB, 12 dB, selectable
Low Level:	-30 to -6 LU

Optional Licence SW20006: RTW Premium PPM plus Vectorscope

High resolution Multistandard-PPM display with advanced scales and with Audio Vectorscope (4 instances available) and Moving Coil instruments (PPM, VU, Loudness, BBC mode). Expands licence SW20001 with Multi-Correlator instrument in multi-channel mode, if activated. For the display of Loudness software licence SW20002 is required.

General

Input sources:	analog, digital, SDI and/or AoIP depending on selected audio interface
Display:	<ul style="list-style-type: none"> ▪ Peak level ▪ Peak hold ▪ Numerical value of the display ▪ Digital Over
Functions:	<ul style="list-style-type: none"> ▪ Gain (+20 dB, +40 dB acc. to standard) ▪ Peak hold on/off ▪ Memory ▪ Reset

Analog Peakmeter Extension

Analog scales:	<ul style="list-style-type: none"> ▪ Zoom10: +10 .. -10, ▪ Zoom1: +1 .. -1, ▪ SMPTE24: +24 .. -30 ▪ SMPTE20: +20 .. -40 ▪ NHK
Integration time:	acc. to standard or 20 ms, 10 ms, 1 ms, 0,1 ms
Peak hold indicator:	1, 2, 4, 10, 20, 30 s, manual reset or off

Digital Peakmeter Extension

Word width:	24 bit
Digital scales:	<ul style="list-style-type: none"> ▪ TP20: +3 .. -20 dB ▪ Dig20: 0 .. -20 dB ▪ Dig0: +18 .. 0 dB ▪ Dig18: +18 .. -18 dB ▪ Dig40: +20 .. -40 dB ▪ ARD9: +9 .. -60 dB ▪ DIN10: +10 .. -50 dB, ▪ Zoom10: +10 .. -10, ▪ Zoom1: +1 .. -1,
Headroom/Headroom Ref:	adjustable from 0 to -20 dB in steps of 1 dB
Operation field:	adjustable from 0 to -20 dB in steps of 1 dB
Integration time (Attack):	acc. to corresponding standard or selectable: Sample, 20 ms, 10 ms, 1 ms, 0,1 ms
Gain:	+20 dB, +40 dB (acc. to standard)
High-pass filter:	Off, 5 Hz, 10 Hz, 20 Hz
Peak hold indicator:	1 s, 2 s, 4 s, 10 s, 20 s, 30 s, manual reset or off
Over indicator hold time:	1 s or manual
Over indicator PPM	
- Threshold:	Full Scale, Full Scale -1LSB, Full Scale -2LSB, -0.1 dBFS, -0.5 dBFS, -1 dBFS, -2 dBFS, -3 dBFS
- Attack time:	1 to 15 samples
- Word width:	16 to 24 bit, selectable
Over indicator True Peak	
- Threshold:	adjustable

Specifications (continued)

Moving Coil Instrument

(available in stereo mode only)

Type: PPM (L/R), PPM (M/S), VU, Loudness, PPM + Loudness (L/R; M, S, or I), selectable

PPM:

- Ch. arrangement: Dual, Dual + M/S horizontal, Dual + M/S vertical, Stereo horizontal, Stereo vertical
- Scales:
 - BR IIa: 7..1, BR IIa ext: 7..1
 - BR IIb: +12..-12 dB, BR IIb ext: +12..-12 dB
- Integration time: Sample (digital only), 0.1 ms, 1 ms, 10 ms, 20 ms, 150 ms
- Headroom Ref: available with digital sources only: -10 dB; adjustable from 0 to -20 dB in steps of 1 dB only available, if M/S type is selected: M3, M6
- S mode:
- Peak indicator: Off, Peak, True Peak, BR Peak
- BR Peak Threshold: 6 dB,
 - BR IIa: adjustable from 4 to 7 dB in steps of 1 dB
 - BR IIb: adjustable from 0 to 12 dB in steps of 1 dB

VU:

- Ch. arrangement: Stereo horizontal, Stereo vertical
- Scale analog: VU (-20 to +3 dB)
- Scale digital: VU Digital (-20 to +3 dB)
- Lead: 0 dB, adjustable from 0 to 12 dB in steps of 1 dB
- Peak indicator: Off, Peak, True Peak

Loudness:

- Ch. arrangement: Dual, Stereo horizontal, Stereo vertical
- Scales: acc. to Loudness settings
- Integration time: acc. to standard
- Peak indicator: Off, no selectable option available

PPM + Loudness:

- Ch. arrangement: Dual-PPM (as described above) with additional Loudness display (BBC mode) for M, S, or I (selectable) in one instrument
- Scales:
 - PPM: see above
 - Loudness: +9 to -9 LU fixed (mid of scale corresponds to Target Level)

Numerical display: switchable

Audio Vectorscope (4 instances available)

in Surround mode

- (if available):
- Display modes:
 - 2-channel
 - 4-channel (fixed: L-R above, LS-RS below)
 - Inputs: in 2-channel mode selectable, selection depends on selected format; e. g. for 5.1: L/R, LS/RS, L/C, C/R, L/LS, R/RS
 - AGC: fast/slow

in 2-channel Stereo mode

- Inputs: L-R
- AGC: fast/slow
- Grid: L/R or M/S

Multi-Correlator

in Surround mode

- (if available):
- for each channel pair of 3.1, 5.0, 5.1, 7.1 formats
 - LFE mode with 5.1, 7.1 formats to display the correlation between each single channel and LFE channel

- Display: red: negative range, white: "0" range, green: positive range
- Filter: low pass filter switchable (300 Hz)

Optional Licence SW20008: TCR - Timecode Reader

Decoding of SDI embedded or LTC timecode. Timecode display. With an activated licence SW20002 the timecode can be used for loudness and logging applications.

Timecode Reader (TCR)

- Display: numerical display of
- LTC (from analog or digital sources)
 - VITC (from SDI data stream)
- Mode: "Timecode" selectable when creating an audio group (constitutes a separate audio group)
- Input: one analog, digital or SDI channel selectable, depending on audio interface being mounted
- Colors: selectable, 32 colors

Loud. Recal. (Loudness Recalculation)

Settings for operating automatic, semi-automatic or manual loudness measurements (Loudness Test Time Control).

- Display: numerical display of
- current timecode
 - start time < current timecode < stop time with recalculation

Start:

- Functions: Autostart after preset load, autostart with gate, autostart with gate and autoreset, manually via keys or GPI. With Timecode Reader licence (SW20008) activated additional control via timecode resp. timecode with recalculation.

- Level for gate: -70,0 LUFS/LKFS; adjustable from -85 to -10 LUFS/LKFS in steps of 0.5 LUFS/LKFS

Stop:

- Functions: manually via keys or GPI, autostop with gate, autostop with gate and time. The stop function is automatically set and fixed to timecode, if the start function has been set to a timecode option.

- Level for gate: -70,0 LUFS/LKFS; adjustable from -85 to -10 LUFS/LKFS in steps of 0.5 LUFS/LKFS

- Time for gate: 1 s; adjustable from 1 to 15 s in steps of 1 s

Optional Licence SW20013: BLITS

Tool to generate line test signals according to EBU 3304, GLITS and BLITS definition. Automatic and significant analysis of channel allocation, level, phase and delay, and polarity of received BLITS 5.1 test signals.

--- Precondition: Software licence SW20001 is activated. ---

Generator

- Functions:
- Line test signal generators for BLITS, GLITS, EBU 3304
 - Optional intro from stored WAV file

Display: Channel related course of outgoing generator sequence

Signal level: -18 dBFS nominal

Level offset: 0 dB; adjustable from -12 to +12 dB in steps of 1 dB

Outputs: digital using the output routing



Specifications (continued)

Analyzer

Functions:	<ul style="list-style-type: none"> Automatic detection and analysis of incoming BLITS test signals
Displays:	Channel related for incoming BLITS test signals
- Course:	Bars for fast and easy recognition of
- State/Alarm:	<ul style="list-style-type: none"> General signal state Channel allocation Level Phase and Delay Polarity
- Report:	<p>In cases of error, the bars will be displayed in red</p> <p>Schedule showing values for</p> <ul style="list-style-type: none"> incoming channels channel allocation measured level in dBFS detected differences in dB Phase and Delay in deg and ms Polarity <p>Values showing differences or errors will be displayed in red</p>

Optional Licence SW20014: Logging Data Server

Export of measured data via IP connection or USB flash drive. Advanced graphical presentation and two-stage definition of thresholds. Communication with RTW LQL PC software. Loudness Chart instrument
 --- Precondition: Licence SW20002! ---

Logging Instrument

Functions:	<ul style="list-style-type: none"> Logging of Loudness and TruePeak data of two audio groups Storing of data on USB flash drive or via IP with LQL - Loudness Quality Logger PC software Definition of main and secondary limits (individual markers) for Mmax, Smax, I and TPmax to monitor the adherence of e. g. legal regulations, current standards or in-house regulations Data collection control automatically via LQL (IP mode) or manually via control key (USB mode)
Mode:	selectable: off, USB, IP
Display:	<p>Status display in the top line of the instrument placed on the screen:</p> <ul style="list-style-type: none"> in IP mode: LQL access in USB mode: Disk space, running processes, storing if logging functionality is turned off
Identification for network:	Device name and password definable
Key function (USB):	<ul style="list-style-type: none"> USB run: Start logging USB close: Stops logging and creates a logfile on the USB flash drive

Loudness Chart Instrument

Functions:	<ul style="list-style-type: none"> Horizontal running bargraphs with individually definable colors evaluate the common quality of Loudness values TP, M, S, I Progress of a measurement (value over time) of up to four values can be drawn as graph(s) on a coordinate system Position of the Relative Gate switchable, color adjustable Adjustable time ranges
------------	--

Display:	<ul style="list-style-type: none"> Selectable time periods for evaluation Vertical Integrated bargraph switchable Tolerance levels and its display adjustable Bargraph: Color change of the running bargraph indicates the section the loudness value is moving in: normal, operation range, Headroom, Over, invalid (availability depending on selected value) Chart-Graph: Continuously drawn graph (value over time) either of one value as line or rectangle with colored filling corresponding to the color selection of the horizontal bargraphs or of up to four values as line, dots, or rectangles without filling with individual color selection; added with Tolerance Indicator or position of Relative Gate (if selected)
Color:	<ul style="list-style-type: none"> Bargraph: Individual selectable colors (32) for Normal (bargraph color), Operation Range, Headroom (TP only), TP Over (TP only), Over (M, S, I only), Invalid (M, S, I only) Chart graph: For each value individual selectable colors (32) for display modes without filling, bei Darstellung ohne Füllung, otherwise adoption of corresponding bargraph colors, additional selectable colors for Tolerance Indicator and position of Relative Gate
Time Range:	<p>Time grid adjustment for the coordinate system and the horizontal bargraphs:</p> <ul style="list-style-type: none"> Increase or decrease of the preset time period in steps of one unit or ten units Magnification of the measured course to the available width of the instrument's window
Time Range presets:	<ul style="list-style-type: none"> - Auto stretch: Automatic stretch of a stopped loudness measurement to the available width of the instrument's window, switchable (except when controlled via timecode) - Hours: 0 h; adjustable from 0 to 3 h in steps of 1 h - Minutes: 1 m; adjustable from 1 to 59 m in steps of 1 m
Time Select:	<ul style="list-style-type: none"> Selection of current time period (marker) Increase or decrease of the marker in step sizes corresponding to the current time grid Shift of the marker and magnification of the content
Tolerance Levels:	<ul style="list-style-type: none"> - TP Headroom: -9.0 dB; adjustable from 0 to -20 dB in steps of 0.1 dB - TP Over Sensitivity: 0.0 dB; adjustable from 0 to -20 dB in steps of 0.1 dB - M High: +1.0 LU; M tolerance above Target Level adjustable from 0 to 10 LU in steps of 0.1 LU - M Low: -1.0 LU; M tolerance below Target Level adjustable from 0 to -12 LU in steps of 0.1 LU - S High: +1.0 LU; S tolerance above Target Level adjustable from 0 to 10 LU in steps of 0.1 LU - S Low: -1.0 LU; S tolerance below Target Level adjustable from 0 to -12 LU in steps of 0.1 LU - I High: +1.0 LU; I tolerance above Target Level adjustable from 0 to 10 LU in steps of 0.1 LU - I Low: -1.0 LU; I tolerance below Target Level adjustable from 0 to -12 LU in steps of 0.1 LU

Specifications (continued)

Optional Licence SW20015: ISA - Immersive Sound Analyzer

Dynamic display for visualizing the interaction of all signal parameters of spatial (immersive) surround formats like 5.1.2, 5.1.4, 7.1.2 or 7.1.4 corresponding to the subjective listening impression across two layers (beds)

--- Precondition: Software licences SW20001, SW20002, and SW20004 are activated. ---

Immersive Sound Analyzer

Display:

- Designed for Immersive audio formats based on 5.1 or 7.1 main beds and 2.0 or 4.0 upper beds
- Graphical display indicating single channel and total program loudness (Total Volume Indicator)
- Position and width of phantom sound sources (PSI) in Main- and Upper Beds
- Phase Correlation between adjacent channels
- Separate correlators for the outer adjacent channels
- Subjectively perceived acoustic focal point with the Dominance Indicator (DMI) for both Main- and Upper Beds
- Subjectively perceived acoustic focal point in the complete immersive area with the Immersive Dominance Indicator (IDI)
- LFE Phase warning (warns in case of negative correlation between any channel and LFE)
- Allows cross-group measurement of the total loudness of the spatial sound image
- Formats Supported: 5.1.2, 5.1.4, 7.1.2, 7.1.4

Items of Delivery

TouchMonitor TM7 20700:

- TM7 main unit in a table-top frame
 - selected audio interface (see page 4)
 - Basic software (system/2 x Stereo-PPM)
 - Table-stand, mains adapter, manual
- Order no.: 20700 + HW-No. (page 4)**

TouchMonitor TM7 20700OEM:

- TM7 main unit without table-top frame
 - selected audio interface
 - Basic software (system/2 x Stereo-PPM)
 - Manual
- Order no.: 20700OEM + HW-No. (page 4)**

TM7-RAV:

- TM7 in table-top frame with audio interface for 32 Ravenna/AES67/ST 2110 AoIP network channels (2 x RJ-45)
 - Power supply: 12 - 24 V DC, 24 VA
 - Basic software (system/2 x Stereo-PPM)
 - Table-stand, mains adapter 24 V, manual
- Order no.: TM7-RAV**

TM7-Dante:

- TM7 in table-top frame with audio interface for 32 Dante® AoIP network channels (2 x RJ-45)
 - Power supply: 12 - 24 V DC, 24 VA
 - Basic software (system/2 x Stereo-PPM)
 - Table-stand, mains adapter 24 V, manual
- Order no.: TM7-Dante**

TM7-Video:

- TM7 in table-top frame with audio interface for 8-ch. digital inputs and outputs (4 x AES3 In/Out, Sub-D) and 3G-/HD-/SD-SDI In/Through (2 x BNC)
 - Basic software (system/2 x Stereo-PPM)
 - Table-stand, mains adapter, manual
- Order no.: TM7-Video**

TM7-Studio:

- TM7 in table-top frame with audio interface for 8-ch. analog inputs (Sub-D) and 8-ch. digital inputs and outputs (4 x AES3 In/Out, Sub-D)
 - Basic software (system/2 x Stereo-PPM)
 - Table-stand, mains adapter, manual
- Order no.: TM7-Studio**

TM7-Rack:

- TM7 without table-top frame with audio interface for 8-ch. digital inputs and outputs (4 x AES3 In/Out, Sub-D) and 3G-/HD-/SD-SDI In/Through (2 x BNC)
 - Basic software (system/2 x Stereo-PPM)
 - Manual
- Order no.: TM7-Rack**

TM7-Mount:

- TM7 without table-top frame with audio interface for 8-ch. analog inputs (Sub-D) and 8-ch. digital inputs and outputs (4 x AES3 In/Out, Sub-D)
 - Basic software (system/2 x Stereo-PPM)
 - Manual
- Order no.: TM7-Mount**

Additional Hardware Options

- 3U mounting adapter **TM7-MA3U**, mounting kit including a 19"/3U/42HP rack-mount panel (half-19"/3U) and fastening material for mounting 20700OEM into standard 19" sub-racks (e. g. RTW 1647831)
- VID mounting adapter **TM7-MAVID**, mounting kit including a half-19"/3U plug-in panel and fastening material for mounting 20700OEM into standard 19" rack-mount cabinets for video racks
- Table-top Mounting Adapter **TM7-MADT**, Mounting kit including a table-top frame, robust swivel-mounted table-stand, housing cover, and mounting material for remodelling 20700OEM to a table-top unit.
- 19"/3U rack frame **1647831** for mounting up to 2 TM7-Mount or 20700OEM in conjunction with TM7-MA3U mounting kit. Includes a blank panel to cover unused space.



Specifications (continued)

Optional Software Licences

- Software licence **SW20001: Multichannel Mode** for the display of multi-channel modes
- Software licence **SW20002: Loudness and SPL Display** for Loudness, SPL and LRA measurements. *)
- Software licence **SW20003: RTA - Real Time Analyzer** for the display of the spectral frequency distribution. *)
- Software licence **SW20004: SSA - Surround Sound Analyzer** to understand the balance of surround programmes intuitively. *)
--- Precondition: Licences SW20001, SW20002! ---
- Software licence **SW20005: Radar Display** for the display of the Loudness-Radar-Meter of TC electronic®. *)
--- Precondition: Licence SW20002! ---
- Software licence **SW20006: RTW Premium PPM + Vektorskop** for the display of further PPM-scales, Moving Coil instruments and audio vectorscope. Expands licence SW20001 with Multi-Correlator.
- Software licence **SW20008: Timecode Reader** for the display of SDI embedded or LTC timecodes, recalculation
--- Precondition: Licence SW20002! ---
- Software licence **SW20013: BLITS** to use BLITS analyzer and BLITS, GLITS, EBU 3304 line test signals.
--- Precondition: Licence SW20001! ---
- Software licence **SW20014: Logging Data Server** for the export of measured data via IP or USB flash drive, two-stage definition of thresholds, advanced graphical presentation with RTW LQL PC software, Loudness Chart instrument *)
--- Precondition: Licence SW20002! ---

- Software licence **SW20015: ISA - Immersive Sound Analyzer** to understand the balance of immersive surround programmes intuitively and for cross-group Loudness measurement.
--- Precondition: Licences SW20001, SW20002, and SW20004! ---
- Software licence **SW20021: TC-RTW** for the conversion of TC electronic® TouchMonitor devices to RTW units. Allows the installation of upcoming licences with new product functionalities on these devices.
--- Precondition: TouchMonitor devices of TC electronic®! ---

*) Licence SW20001 is required for the display of more than 4 channels.

Optional accessory

- Wide voltage power supply **1178-R** (100 - 240 V AC/24 V DC 2,7 A, table-top unit with corresponding mains cable for different power systems)
- Snake cable **1167** (4 m, 25-pin Sub-D-M connector to 4 x XLR-M and 4 x XLR-F connectors, for digital inputs and outputs)
- Snake cable **1186** (4 m, 25-pin Sub-D-M connector to 8 x XLR-F connectors, for analog inputs)

Product Line-up

TouchMonitor TM7 table-top unit

7" touch screen 16 : 9 TFT, main unit with table-top frame, table-stand, power supply. Order number: **20700 + ...**

Additional audio interface required:

TouchMonitor TM7 OEM unit

7" touch screen 16 : 9 TFT, main unit w/o table-top frame, w/o power supply for panel-mounting.

Order number: **20700OEM + ...**

Additional audio interface required:

3U Mounting Adapter TM7-MA3U

Mounting kit including a 19"/3U/42HP rack-mount panel (half-19"/3U) and fastening material for mounting 20700OEM into standard 19" sub-racks.

VID Mounting Adapter TM7-MAVID

Mounting kit including a half-19"/3U plug-in panel and fastening material for mounting 20700OEM into standard 19" rack-mount cabinets for video racks.

Table-top Mounting Adapter TM7-MADT

Mounting kit including a table-top frame, robust swivel-mounted table-stand, housing cover, and material for remodelling 20700OEM to a table-top unit.

Audio Interface Selection (I/O)	Max. Channel Count (Hardware)	Inputs Analog (Balanced)	Inputs Digital/Outputs Digital	Audio via Network (AoIP)
additional Order Number: HW20711	8-channel analog In, 8-channel digital In, 8-channel digital Out	1 x 25-pin Sub-D	1 x 25-pin Sub-D (4 x AES3 In, 4 x AES3 Out)	---
additional Order Number: HW20712	8-channel analog In, 8-channel digital In, 8-channel digital Out	1 x 25-pin Sub-D	8 x BNC (4 x AES3id In, 4 x AES3id Out)	---
additional Order Number: HW20714	3G-SDI In, 3G-SDI Through, 8-channel digital In, 8-channel digital Out	---	2 x BNC (3G-SDI In/Through), 1 x 25-pin Sub-D (4 x AES3 In, 4 x AES3 Out)	---
additional Order Number: HW20715	16-channel digital In, 16-channel digital Out	---	2 x 25-pin Sub-D (8 x AES3 In, 8 x AES3 Out)	---
additional Order Number: HW20717	32-channels Dante™ AoIP	---	---	2 x RJ-45 (Dante® network) (Link/Act 1G, Primary and Secondary)
additional Order Number: HW20718	32-ch. Ravenna/AES67/ST 2110 AoIP	---	---	2 x RJ-45 (Ravenna network) (Link/Act 1G, Primary and Secondary)

Standard Hardware:

Table-top unit with easy-to-use graphical interface, Ethernet, 2 x USB, GPIO, VGA Out, table-stand, mains adapter. Audio Interface Selection required!
OEM unit with easy-to-use graphical interface, Ethernet, 2 x USB, GPIO, VGA-Out. Audio Interface selection is required!

Standard Software:

Basic 4-channel PPM with analog scales (DIN +5, Nordic, British Ila, British I Ib) and digital scales (0 to -60 dB, +3 to -60 dB True Peak, DIN, Nordic, British Ila and I Ib), stereo correlator, gain reduction, global keyboard. Other software modules available as licences.

Preconfigured Models (Table-top- or panel-mount units with specific audio interface for typical applications. We recommend licences SW20001, SW20002, SW20004, SW20006 as basic configuration.)

TM7-RAV	32-ch. Ravenna/AES67/ST 2110 AoIP	---	---	2 x RJ-45 (Ravenna network) (Link/Act 1G, Primary and Secondary)
TM7-Dante	32-channels Dante™ AoIP	---	---	2 x RJ-45 (Dante® network) (Link/Act 1G, Primary and Secondary)
TM7-Video (Table-top with psu)/ TM7-Rack (Panel-mount w/o psu)	3G-SDI In, 3G-SDI Through, 8-channel digital In, 8-channel digital Out	---	2 x BNC (3G-SDI In/Through), 1 x 25-pin Sub-D (4 x AES3 In, 4 x AES3 Out)	---
TM7-Studio (Table-top with psu)/ TM7-Mount (Panel-mount w/o psu)	8-channel analog In, 8-channel digital In, 8-channel digital Out	1 x 25-pin Sub-D	1 x 25-pin Sub-D (4 x AES3 In, 4 x AES3 Out)	---

Licences (Software Modules) Further information on <https://www.rtw.com/en/product-list/audio-monitors/licenses-for-touchmonitor.html>

Multichannel Mode Order Number: SW20001	Loudness and SPL Display Order Number: SW20002 *	RTA - Real Time Analyzer Order Number: SW20003 *	SSA - Surround Sound Analyzer Order Number: SW20004 * Precondition: installed SW20001, SW20002!	Radar Display Order Number: SW20005 * Precondition: installed SW20002!	Premium PPM plus Vectorscope Order Number: SW20006 . Expands SW20001 with Multi-Correlator
Timecode Reader Order Number: SW20008 * Precondition: installed SW20002!	BLITS (Analyzer and Generator) Order Number: SW20013 * Precondition: installed SW20001!	Logging Data Server Order Number: SW20014 * Precondition: installed SW20002!	ISA - Immersive Sound Analyzer Order Number: SW20015 Precondition: SW20001, SW20002 and SW20004 installed!	TC-RTW (Conversion Kit) Order Number: SW20021 Precondition: TM of TC electronic®!	

* Licence SW20001 is required for the display of more than 2 channels.

Dimensions:

W x H x D in mm (approx.)

Table-top units 20700, TM7-Dante, TM7-Video, TM7-Studio: 198 x 139.5 (163) x 46 (95) (with table-stand)

20700OEM, TM7-Mount: 188 x 109 x 45

TM7-Rack: 42HP (213 mm) x 3U (129 mm) x 44.5 mm



Gefördert vom Bundesministerium für Wirtschaft und Technologie aufgrund eines Beschlusses des Deutschen Bundestages.
Translation: Due to a resolution of the German Parliament this project is supported by the German Federal Ministry of Economy and Technology.

RTW US Corp.

160 Varick St | 3rd Floor | New York NY 10013

Phone: +1 (646) 458 1423

ussales@rtw.com | www.rtw.com

RTW
EYES ON YOUR AUDIO